

## Peripheral Connections

### Wiring of Alarm Input

The alarm input is an open/closed relay. To connect the alarm input to the device, use the following diagram.



If the alarm input is not an open/close relay, please connect an external relay between the alarm input and the device.

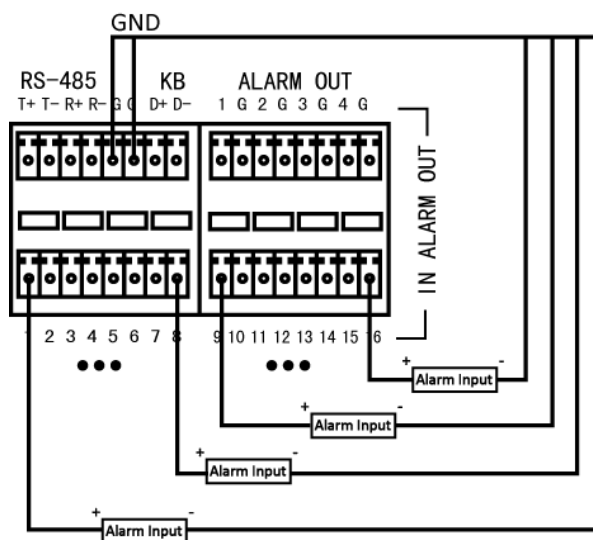

### Wiring of Alarm Output

To connect to an alarm output (AC or DC load), use the following diagram:

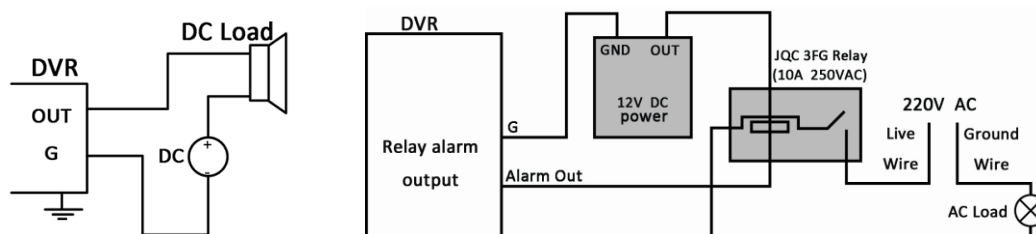

**DC Load Connection Diagram**

**AC Load Connection Diagram**

For DC load, the jumpers can be used within the limit of 12V/1A safely.

To connect an AC load, jumpers should be left open (you must remove the jumper on the motherboard in the DVR). Use an external relay for safety (as shown in the figure above).

There are 4 jumpers (JP1, JP2, JP3, and JP4) on the motherboard, each corresponding with one alarm output. By default, jumpers are connected. To connect an AC load, jumpers should be removed.

**Example:**

If you connect an AC load to the alarm output 3 of the DVR, then you must remove the JP 3.

### Alarm Connection

To connect alarm devices to the DVR:

1. Disconnect *pluggable block* from the ALARM IN /ALARM OUT terminal block.
2. Press and hold the orange part of the *pluggable block*; insert signal cables into slots and release the orange part. Ensure signal cables are in tight.
3. Connect *pluggable block* back into terminal block.